



## **The Effects of Cooperative Learning Model on Students' Epistemological Beliefs in Civics Lesson**

**Assist.Prof.Dr. Ufuk ŞİMŞEK**  
Ataturk University-Turkey  
ufukersegun@gmail.com

### **Abstract**

The purpose of this study was to investigate the effects of cooperative learning model and teacher centred method on students' epistemological beliefs in civics lesson. This research included 193 second-graduate students from four classes of a civics lesson taught by the researcher in a faculty of education in a university in the 2011-2012 academic years. For this research, four treatment classes were selected. Treatment classes were selected as the Group Investigation Group (GIG) (n=48), the Reading-Writing-Presenting Group (RWPG) (n=49) and the Jigsaw Group (JG) (n=48), used in application cooperative learning model and Teacher Centred Group (TCG) (n=48), in which the teacher centred learning method was applied. The data was collected through Epistemological Beliefs Questionnaire (EBQ). At the end of the study was not observed differences in terms of development and changes of epistemological beliefs of the students in the treatment groups. However, when we look effect size the results obtained of treatment groups, methods RWP and JG observed positive impact on students' epistemological beliefs than others.

**Keywords:** Cooperative learning; Epistemological beliefs, Higher education, Civics lesson

### **INTRODUCTION**

In today's world, one of the main conditions to be improved and sustainable society is to have a population knowledge-producing, using and questioning. In order to have such a population, the appropriate training is required. Approach to education which accepts teacher and textbook as a source of information, considered the information does not change is not possible to train human resources with the required age. Therefore, at all stages of education, it is inevitable that individual an active, critical and inquisitive, engaged to be based on student-centered approaches (Murdoch and Jeni, 2008; Handelsman et al., 2007; Preszler et al., 2007).

Educational researchers have attempted to investigate how students know, how the nature of knowledge and knowing is related to students' learning, and how students' epistemological beliefs inform classroom instruction in different content areas (Carey et al., 1989; Hammer, 1995; Larochelle and Desautels, 1991; Qian and Alvermann, 1995). Since the late 80s, there has been a growing literature on teachers' beliefs including beliefs about education, beliefs about teaching and learning, and beliefs about teacher efficiency (Fang, 1996). Numerous studies confirm that there are strong connections among teachers' beliefs, their classroom behaviours, and the learning environment.





Research on beliefs about the nature of knowledge and knowledge acquisition is not plentiful. There has been a growing interest in understanding what teachers believe about the nature of knowledge and learning (Flores, 2001; Howard et al., 2000; Schommer, 1990). There is also another body of research that indicates that effective learning may be influenced by a somewhat different set of beliefs. These are called epistemological beliefs and refer to beliefs individuals have about the nature and acquisition of knowledge (Bendixen, Dunkle and Schraw, 1994).

Epistemological beliefs are those concerning the nature of knowledge and knowing, including definitions of knowledge, how knowledge is constructed, and how knowledge is evaluated. These beliefs are linked to cognitive processes such as reading comprehension, learning in complex and ill-structured domains (Schommer, 1994). A growing body of work provides evidence that personal epistemology is an important component of student learning (Hofer, 2001)

Epistemic beliefs are individuals' basic assumptions about the nature of knowledge and about appropriate ways to develop one's own and others' knowledge (Schommer, 1990). Schommer (1998) presented evidence that elaboratedness of a person's system of epistemic beliefs has many substantial implications for learning:

- Students, who believe that learning occurs quickly, tend to read texts more superficially.
- Students, who believe that knowledge is certain, tend to learn facts by heart rather than understanding the meaning of the to-be-learned.
- Students, who believe that learning capabilities are determined by innate abilities, show less interest in activities designed to master complex challenges.
- Students who trust authorities do not tend to challenge the sources of information

In Schommer's hypothetical framework, epistemological beliefs vary along a continuum, from naive to sophisticated beliefs. A teacher who holds naive epistemologies generally believes that knowledge is simple, clear and specific; knowledge resides in authorities and is certain and unchanging; concepts are learned quickly or not at all and learning ability is innate and fixed. A teacher who holds sophisticated epistemologies along the five dimensions believes that knowledge is complex, uncertain and tentative; knowledge can be learned gradually through reasoning processes and can be constructed by the learner (Howard et al., 2000; Schommer, 1994). Schommer's (1990) dimensions of epistemology are evident in the studies about teachers' beliefs about teaching and learning (Samuelowicz and Bain, 1992). Schommer and others have suggested that epistemological beliefs are related to meta-cognitive activities such as reading comprehension, including comprehension monitoring, interpretation of information (Kardash and Scholes, 1996; Schommer, 1990; Schommer, Crouse and Rhodes, 1992). Teacher epistemological beliefs/epistemology has been found to affect teachers' use of teaching strategies and their openness to student alternative conceptions (Hashweh, 1996; Pajares, 1992). From this, it may be deduced that there may be particular relations between teacher's epistemological beliefs and their conceptions about teaching and learning. Teacher





educators may also make use of the relations between epistemological beliefs and conceptions about teaching and learning to effect desirable changes within student teachers. Teacher educators could help student teachers make their epistemological beliefs explicit and help them to articulate how their beliefs affect conceptions about teaching and learning. In exploring these questions, epistemological beliefs are defined to be beliefs about the nature of knowledge and knowing/learning. The definition was adopted from Schommer (1990, 1994) and this definition has been commonly used by other researchers (Hofer and Pintrich, 1997; Jehng, Johnson, and Anderson, 1993). There are two fundamental conceptions of teaching and learning that the traditional and the constructivist (Clements and Battista, 1990). Supporters of the traditional conception believe that the classroom learning context in which the teacher plays the major role in knowledge transmission supports and yields the most efficient and effective learning process and outcomes. Constructivism has its origins in Piagetian theory that refers to the belief that people actively construct their perspectives by interpreting their experiences (Kegan, 1982). Advocates of constructivism suggest that knowledge is created from and by the interaction between students, or between students and teachers (Kember, 1997). The first orientation is teacher-centred and focuses upon the communication of defined bodies of content or knowledge. The second orientation is student-centred and hence focuses towards the students' learning. The latter orientation takes a developmental approach towards students and their conceptions of knowledge. The traditional conception of teaching is often referred to using teacher-centred teaching strategies because knowledge acquisition is affected through a one-way transmission process from the teacher to students, with limited interactive processes between students and teachers; student-centred teaching strategies that emphasize the student's self-motivation, self-reflection and that learning is a reflective and interactive process in which the role of the teacher is a facilitator. Many researchers are identified as being in line with constructivist views (Entwistle et al., 2000; Trigwell et al., 1999). Studies show that if a teacher adopts a more student-centred approach to teaching, the students will be more likely to adopt a deep approach to learning that seeks deeper meanings and understandings of what they are studying (Entwistle et al., 2000; Trigwell et al., 1999). The constructivist learning model/conception emphasizes the creation of active learning environments that permit critical thinking, discovery, and collaboration. In contrary, the traditional/ transmissive learning model views the teacher as the source of knowledge and students as passive recipients of knowledge. Such model/conception emphasizes learning by receiving information, especially from the teacher and from textbooks, to help students encounter and learn welldefined concepts (Howard et al., 2000; Prawat, 1992).

The constructivist mode of learning may be associated with teachers having sophisticated epistemologies, and an orientation to the traditional/ transmissive conception may be reflective of teachers holding naive epistemologies associated with omniscient authority and certain knowledge. It is likely that Schommer's sophisticated epistemologies are parallel to a constructivist conception, while Schommer's naive epistemologies are parallel to a traditional/transmissive conception. An exploratory study of the relationships between epistemological beliefs and conceptions about teaching and learning may help validate these assumptions. Etchberger and Shaw (1992), for example, traced the change in a science teacher's beliefs about teaching and





learning and how these beliefs influenced her teaching methods. The teachers' teaching practices that relied on the lecture method and the mere presentation of information were traced to the realist conception of knowledge that these teachers held (Benson, 1989).

Hashweh (1985) showed that constructivist teachers had a richer repertoire of teaching strategies than nonconstructivist teachers and that these constructivist teachers tended to use teaching strategies that were potentially more effective in inducing conceptual change.

Increasingly, educational and instructional psychologists have also become interested in how a student's underlying beliefs about knowledge and knowing are a part of the process of learning, and how these beliefs affect or mediate the knowledge-acquisition and knowledge-construction process. What students think knowledge is and how they think they know have become critical components of understanding student learning? For example, beliefs about the nature of knowledge may influence strategy use (Schommer, Crouse and Rhodes, 1992), cognitive processing (Kardash and Howell, 2000) and conceptual change learning (Qian and Alvermann, 2000).

One study found that there was a possible influence of the four epistemological beliefs on the two conceptions about teaching and learning (Chan and Elliott, 2004). Accordingly, traditional conception accepts knowledge as innate/fixed ability, authority/expert knowledge and certainty knowledge and constructivist conception as learning effort/process.

The Educational curriculum of all countries in today's education can be described as constructivist approach in terms of its perspective (Richardson, 2005; Erdem and Demirel, 2002) In reviewing literature deal with epistemological beliefs, previous studies show that there are structural relationships between epistemological beliefs and learning approaches (Rodríguez and Cano, 2006).

Hypotheses about the relationship methods-epistemological beliefs:

**Ho:** There is no significant relationship between students' epistemological beliefs and cooperative learning methods.

**H<sub>1</sub>:** There is a significant relationship between students' epistemological beliefs and cooperative learning methods.

## METHOD

This is a quasi-experimental study and designed as a Non-Equivalent Groups pre-test, post-test, and comparison group model. In this design, participants are not randomly assigned to the groups; instead, there are naturally occurring groups or groups to which participants are assigned for reasons other than randomizing the sample. The study utilized "a pre-test/post-test non-equivalent comparison group design (McMillan and Schumacher, 2006). Quasi-experimental study is a type of evaluation which aims to determine whether a program or intervention has the intended effect on a study's participants. Quasi-experimental studies take on many forms, but may best be defined





as lacking key components of a true experiment. While a true experiment includes (1) *pre-post test design*, (2) a *treatment group* and a *control group*, and (3) *random assignment* of study participants, quasi-experimental studies lack one or more of these design elements. Since the most common form of a quasi-experimental study includes a pre-post test design with a treatment group and a control group, quasi-experimental studies are often an impact evaluation that assigns members to the treatment group and control group by a method other than random assignment (Pronzato, 2012).

The sample of this study consisted of a total of 193 second-graduate students from four different classes enrolled in the civics lesson for the 2011–2012 academic years. Groups created taking into account the final grade point average. These students, a central examination took approximately the same scores. Students are between the ages of 19 and 23. One of the classes was selected as the Group Investigation Group (GIG) ( $n=48$ ), in which the group investigation method was applied; the second was selected as the Reading-Writing-Presenting Group (RWPG) ( $n=49$ ), in which the reading-writing-presenting method was applied; the third was selected as the Jigsaw Group (JG) ( $n=48$ ), in which the Jigsaw method was applied; and the four was selected as the Teacher Centred Group (TCG) ( $n=48$ ), in which the teacher centred learning method was applied.

**Instruments:** The data was collected through Epistemological Beliefs Questionnaire (EBQ). Epistemological Beliefs Questionnaire (EBQ) developed by Schommer (1990) and the Turkish reliability invention were made by Deryakulu and Büyüköztürk (2002). Under the four-factor structure in the original scale of Schommer, There are 63 items in total. The names of factor of the scale are Innate Ability, Quick Learning, Simple Knowledge and Certain Knowledge. Students who answer of the scale marks the participate levels to each item on a rating schedule in 5-Likert type ranging from (1) Strongly Agree to (5) Strongly Disagree. The high scores obtained from the original scale indicate that Students have epistemological beliefs undeveloped / immature (naive) while the low scores obtained from the scale indicate to be developed / matured (sophisticated) of the students' epistemological beliefs. In this study, the new form of EBQ consisting of 34 items at under the three-factor structure, adapted to Turkish and developed by Deryakulu and Büyüköztürk (2002), was used. Three factors in this new form was named as the belief that first factor consisting of 18 items is the belief that learning depends on effort, second factor consisting of 9 items is the belief that learning depends on ability and third factor consisting of 8 items is there were only one truth. This aspect it, the first two-factor of the scale measures beliefs conflict to learning and the third factor measures beliefs regarding the information. The reliability studies of EBQ were repeated with the data obtained by the reliability study a sampling of 595 students that receive education in the different four State University. Additionally, the Cronbach Alpha inner consistency coefficient calculated according to the item analysis of the scale is found to be 0.83 for the first factor, 0.62 for the second factor, 0.59 for the third factor and 0.71 for the whole scale. The highest score on this test is 170 points.



**Procedure:** Students from four the treatment group studied the topics of the civics lesson during the same period of time in different instructional method (The Reading-Writing-Presenting Method, The Group Investigation Method, The Jigsaw Method and The Teacher Centered Learning Method). The subjects in four groups took the “civics lesson” lesson for six weeks (two hours per week). The teaching in four groups was carried out by the author, a Social science researcher.

**The Reading-Writing-Presenting Method Implemented:** The Reading-Writing-Presenting (RWPG) students were randomly divided into eight sub-groups as shown in Figure 1. These groups were contained six students and one group contained seven students.

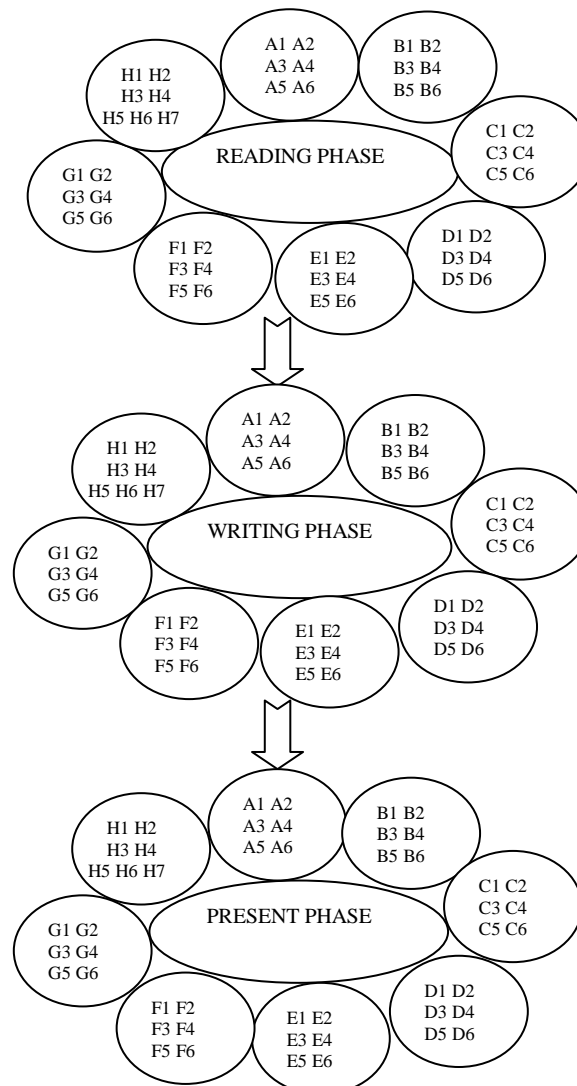

**Figure 1.** Phases of Reading-Writing-Presenting Method

The reading-writing-presenting technique was carried out seven weeks to teaching the “civics lesson”. The main features of the modified reading-writing-presenting technique are presented in three phases for each group in given Figure 1 and namely; 1) in-class reading, 2) in-class writing, and 3) in-class presenting

In class reading; all groups in the classroom read the topics for 30 minute from the course books or other resources which was included in the module for the week.

In class writing; all groups wrote their understanding about what they read for 20 minutes without accessing resources. Writing was done by group pairs. After finishing the writing, the notes written by the groups were evaluated by the author. Groups whose evaluated outcomes were not good enough sent back to groups for reading stage.

After the groups finished reading and writing stages, three groups made presentations about the subject for 20 minutes. Then, after the presentation an argument discussed in the classroom. In this group, the acquisition of the knowledge on the subject by the students is provided with the implementation of the RWP method.

**The Group Investigation Method Implemented:** The Group Investigation students were randomly divided into two parts (Part I, n=24 students + Part II, n=24students). The students in these parts were divided into six sub-groups as shown in Figure 2. The topics of civics lesson were dividet into six Subtopics (St1, St2, St3, St4, St5, and St6). In this instance, groups contained four students. The GIG was employed six weeks to teaching of the basic concept in Constitutional developments in the Ottoman-Turks (1808-1961) (St1), The principal properties 1982 Constitution (St2), The fundamental rights and freedoms in 1982 Constitution (St3), Legislation in 1982 Constitutional (St4), Administration in 1982 Constitutional (St5) and Jurisdiction in 1982 Constitutional (St6). The main features of the modified group investigation are presented in three phases for each module as given in below (Oh and Shin 2005; Koc, Doymus, Karacop, and Simsek 2010), namely 1) in-class discussion, 2) out-of-class investigation, and 3) in-class presentation.

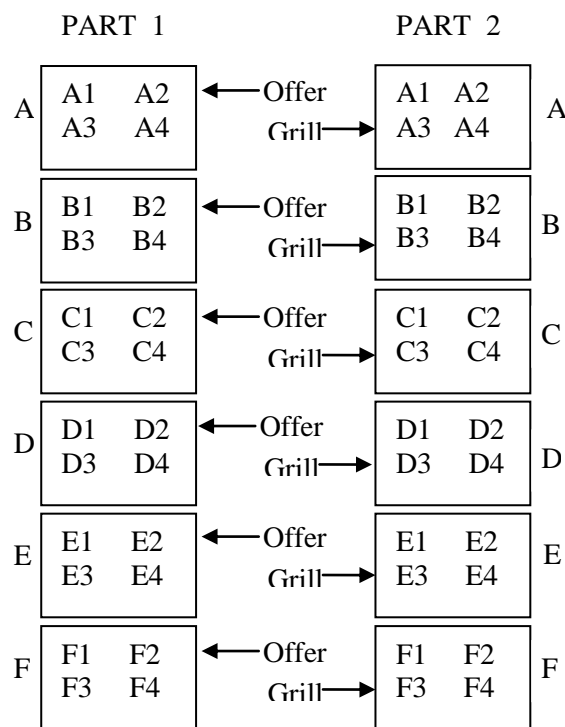

**Figure 2.** Forming of grill and offer groups from parts I and II



In-class discussion: ‘students are organized into research groups’, ‘students get together in their groups for discussion’, ‘each group sets an inquiry topic within a given unit and makes a plan for investigation’, ‘during the discussion, group members use their textbooks to identify their own problems, questions, or issues and select a topic to study’, and ‘the teacher participates in the group discussion and the teacher’s roles include encouraging students to select authentic topics that can be addressed in multiple ways’.

In out-of-class investigation: ‘each student group carries out its investigation’, ‘the teacher helps students with their investigations’, ‘the teacher’s roles include presenting sources of information, providing instruments for their study, and assisting students with difficulties’, and ‘each research group prepares an in-class presentation’.

In-class presentation: Week II: group A in part 1 was the presentation (offer) group while group A in part 2 was the inquiry (grill) group. While group A in part 1 presented the topics of St1, group A in part 2 questioned the group about their presentation and determined their weaknesses. Other students in the classroom also participated in the discussion. Week III: group B in part 2 was the offer group while group B in part 1 was the grill group. While group B in part 2 presented the topics of St2, group B in part 1 questioned the group about their presentation and determined their weaknesses. Other students in the classroom also took part in the discussion. The other grill and offer groups given in Table 1 were organized in the same way as week II and week III.

**Table 1.** Allocation to Weeks and Groups of Modules

Weeks	Grill groups	Offer groups	Present topics
II	Part I A	Part II A	St1
III	Part II B	Part I B	St2
IV	Part I C	Part II C	St3
V	Part II D	Part I D	St4
VI	Part I E	Part II E	St5
VII	Part II F	Part I F	St6

**The Jigsaw Method Implemented:** The jigsaw group students were randomly divided into two parts (24students + 24 students). Figure 3 represents one of these parts (24 students). The other part was organized in the same way as the first. These students were divided into four “home groups” since the civic lesson topic is divided into six subtopics [1) Constitutional developments in the Ottoman-Turks (1808-1961) 2)The principal properties 1982 Constitution 3) The fundamental rights and freedoms in 1982 Constitution 4)Legislation in 1982 Constitutional 5)Administration in 1982 Constitutional 6) Jurisdiction in 1982 Constitutional]. In this instance, each home group contained four students, taking same subtopics; however, the number of home groups in





a class can be increased or decreased so that every student in the class can participate in the jigsaw method.

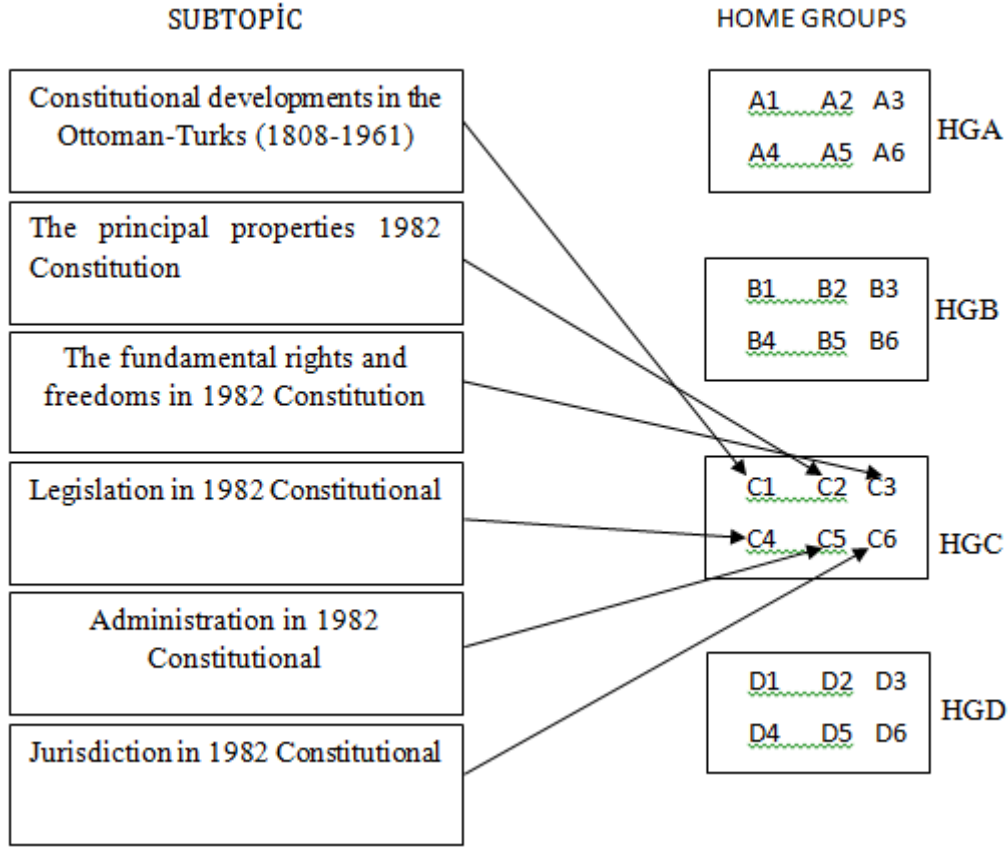
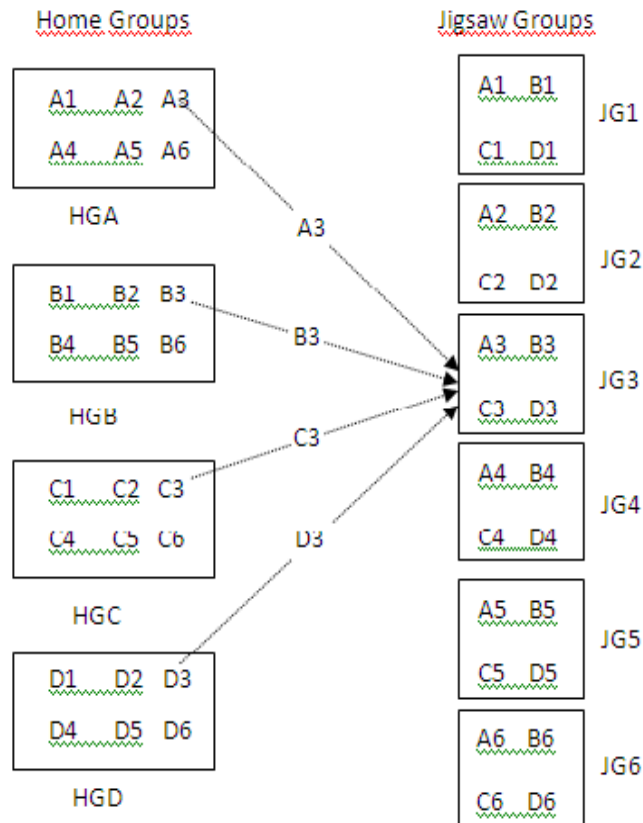

**Figure 3.** Subtopics of the Civics Lesson and Home Groups Representing (A1, A2, A3A4, A5, A6 etc. Stands for an Individual Student from a Group)

Each home group studied their subjects on their own out of class. Then each group was given 30 min to present their work to the class and 20 min for discussion with the class. During this discussion, the home group answered the questions asked by the class. The home groups then broke apart, like pieces of a jigsaw puzzle (Doymus 2008; Mattingly and Van Sickle 1991), and the students moved into jigsaw groups consisting of members from the other home groups who were assigned the same portion of the material. Then the students in the home groups, following the presentation of all subtopics in Civics Lesson, formed jigsaw groups containing JG1, JG2, JG3, JG4 JG5 and JG6 with one student from each of the home groups (see Fig. 4).

In these jigsaw groups, the teacher asked them to familiarize themselves with their subtopic. They prepared summary reports and then each jigsaw group prepared a teaching strategy for its members to use to explain their subtopic to the rest of the class. Each jigsaw group presented their own Subtopic to the class for 30 min, and then discussed the related topics for 20 min. The students then went back to the home groups. These home groups then consisted of one student from each jigsaw group, and

these students were called “expert students.” The experts were then in charge of teaching their specific subtopic to the rest of the students in their learning group



**Figure 4.** Forming of Jigsaw Groups from Home Groups

**Teacher-Centered Learning Method Implemented:** In this group, the subjects were taught by using the teacher-centered learning method. The researchers planned the presentation activities of the subjects that would be taught during the lesson in a report not by a classical teaching presentation but by giving assignments to students on the subjects of “civics lesson”, and by providing internet addresses and workbooks for constructing the information to be presented to them. The same content was taught in the other groups and the learning objectives were the same. In contrast with the RWPG, GIG and JG students in the TCG were required to use their textbooks; students were passive participants and rarely asked questions. In the teacher-centered learning method, generally the teacher wrote the concepts on the board and then explained them; students listened and took notes as the teacher lectured on the content. In this process, student’s performances were observed and the studies were directed according to the feedback obtained from them. The topics in civics lesson were taught by the authors to the treatment groups two hours per week for seven weeks. Measurement tool was applied to the treatment groups at the end of the study.

## FINDINGS

The data obtained in this study given in Table 2 result of descriptive statistical analyses of the Epistemological Beliefs Questionnaire (EBQ) of treatment groups.

**Table 2.** The result of descriptive statistical analyses of EBQ of treatment groups.

Tests	Groups	N	Mean	S. D.
Pre-EBQ	RWPG	46	112,80	12,450
	GIG	47	110,96	7,434
	JG	48	107,4	10,999
	TCG	47	109,94	14,489
Post-EBQ	RWPG	49	113,31	12,420
	GIG	47	107,85	14,856
	JG	48	109,71	8,440
	TCG	48	111,73	10,728

The data in Table 2 indicate that the mean of pre test scores EBQ among the treatment groups (RWPG, GIG, JG, and TCG) are in a close value to each other. As a reason for this results can be said that students have come from the same educational system. But the mean of post test scores EBQ among the treatment groups seem to differ from each other.

One- way ANOVA related to the total mean scores of the EBQ for the treatments groups are presented in Table 3.

**Table3.** The result of ANOVA analyses of EBQ of treatment groups

		Sum of Squares	df	Mean Square	F	P
Pre-EBQ	Between Groups	820.647	3	273.549		
	Within Groups	24859.879	184	135.108	2.025	.112
	Total	25680.527	187			
Post-EBQ	Between Groups	812.218	3	270.739		
	Within Groups	26313.761	188	139.967	1.934	.125
	Total	27125.979	191			

The data in Table 3 indicate that there were statistically no significant differences in terms of pre tests and post tests scores of EBQ among treatment groups (Pre-EBQ;  $F_{3,187}=2.025$ ,  $p>.05$ ; Post-EBQ;  $F_{3,191}=1.934$ ,  $p>.05$  ). The reason of this may be that students in higher education have a shorter period of work to change the epistemological belief formed over many years. Also; Cohen's  $d$  refers to the multiple correlation coefficient, squared and adjusted for number of independent variables,  $N$ , and effect size, and indicates how much variance or variability in the dependent variable



can be predicted. Cohen's *d* of .10, .36, and .51 denotes small, medium, and large effect sizes, respectively (Cohen, 1988; Leech, Barrett, and Morgan, 2005; Doymus, Karacop, and Simsek, 2010). The effect size was large (Cohen's *d* = .46). Students' epistemological belief on the EBQ was related to the type of group (RWPG or JG and GIG). One possible explanation might be that, with the simple students' epistemological belief that was depicted in this study, the maximum effect was achieved with both the RWP and the Jigsaw methods.

## CONCLUSIONS

In this section are discussed taking into account the findings obtained from the research. Also, the recommendations developed for applicators and researchers included in this section.

At the end of the study was not observed differences in terms of development and changes of epistemological beliefs in the treatment groups. However, when we look effect size the results obtained of treatment groups, methods RWP and JG observed positive impact on students' epistemological beliefs than others.

Work period should be long for more change in epistemological beliefs. It takes a long time for change of the students' attitudes and epistemological belief. Researches on students' attitudes and epistemological belief indicated that students' attitudes and epistemological belief unchanged a shorter working time. Also, in order to monitor change of the students' attitudes and epistemological belief towards science and course required long-term studies (Conley, Pintrich, Vekiri and Harrison, 2004; Azizoğlu ve Çetin, 2009; Uygur, 2009). Furthermore all studies postulate change over time from the so-called naive epistemological beliefs towards sophisticated epistemologies (King and Kitchener, 1994; Schommer 1993; Schommer, Calvert, Gariglietti, and Bajaj, 1997; Kuhn and Weinstock, 2002). For example, an individual initially believes that knowledge is certain and stable, either true or false, and can be handed down by an authority. Over time, he or she becomes convinced that knowledge is more complex and relativistic, accepts the uncertainty and changeability of truth, and shifts to the notion that knowledge is construed individually (Kienhues, Bromme and Stahl, 2008).

In addition, cause of this can be pointed to the standardized attitudes of high school students' access to information and knowledge. The knowledge in the civics lesson is accurate and constant compared to other course in Social Studies Education. Therefore, this case can be seen as a further reason for the stability of students' epistemological belief. If student-centered methods applied to all levels of education, can be said change individuals the attitudes of epistemological. Work in this area suggests that students in constructivist classrooms develop more sophisticated epistemological stances than do those in traditional classrooms (Smith, Maclin, Houghton and Hennessey, 2000) and Constructivist approaches to training teachers may promote epistemological change (Howard, McGee, Schwartz and Purcell, 2000).

The demands of the learning environment impact on students' learning activities. Students' experiences with may influence their epistemological beliefs and conceptions





of teaching and learning. Students' prior beliefs and conceptions should be taken into account with the introduction to cooperative learning. Students who believe in expert knowledge and certainty of knowledge, and hold traditional conceptions of teaching and learning, may not immediately appreciate self-directed learning and working in groups (Otting et all. 2010).

## References

- Azizoğlu, N. ve Çetin, G. (2009). 6 ve 7. Sınıf Öğrencilerinin Öğrenme Stilleri, Fen Dersine Yönelik Tutumları ve Motivasyonları Arasındaki İlişki. *Kastamonu Eğitim Dergisi*, 17 (1):171-182.
- Bendixen, L.D., Dunkle, M.E., and Schraw, G. (1994). Epistemological beliefs and reflective judgment. *Psychological Reports*, 75 (3): 1595-1600.
- Benson, G.D. (1989). Epistemology and science curriculum. *Journal of Curriculum Studies*, 21(4): 329-344.
- Carey, S., Evans, R., Honda, M., Jay, E., and Unger, C. (1989). "An experiment is when you try it and see if it works": A study of grade 7 students' understanding of the construction of scientific knowledge. *International Journal of Science Education* 11 (5): 514-529.
- Chan, K. W., and Elliott, R. G. (2004). Relational analysis of personal epistemology and conceptions about teaching and learning. *Teaching and Teacher Education*, 20 (8): 817-831.
- Clements, D. H., and Battista, M. T. (1990). Constructivist learning and teaching. *Arithmetic Teacher*, 38 (1): 34-35.
- Cohen, J. (1988). *Statistical power analysis for the behavioral sciences* (2nd ed.). New Jersey: Lawrence Erlbaum.
- Conley, M., Pintrich, R., Vekiri I., and Harrison, D. (2004). Changes in epistemological beliefs in elementary science students, *Contemporary Educational Psychology*, 29: 186-204.
- Deryakulu, D. ve Büyüköztürk, Ş. (2002). Epistemolojik İnanç Ölçeğinin Geçerlik Ve Güvenirlik Çalışması. *Eğitim Araştırmaları*, 2 (8): 111-125.
- Doymus, K. (2008). Teaching chemical equilibrium with the jigsaw technique. *Research in Science Education*, 26 (1): 47-57.
- Doymus, K., Karacop, A. and Simsek, U. (2010). Effects of jigsaw and animation techniques on students' understanding of concepts and subjects in electrochemist. *Education Technology Research and Development*, 58 (6): 671-691.
- Entwistle, N., Skinner, D., Entwistle, D., and Orr, S. (2000). Conceptions and beliefs about 'good teaching': an integration of contrasting research areas. *Higher Education Research and Development*, 19 (1): 5-26.
- Erdem, E., and Demirel, Ö. (2002). Program Geliştirmede Yapılandırmacılık Yaklaşımı, *Hacettepe Üniversitesi Eğitim Fakültesi Dergisi*, (23): 81-87.
- Etchberger, M.L., and Shaw, K.L. (1992). Teacher change as a progression of transitional image: A chronology of a developing constructivist teacher. *School Science and Mathematics*, 92 (8): 411-417.
- Fang, Z. (1996). A review of research on teacher beliefs and practices. *Educational Research*, 38 (1) :47-65.
- Flores, B. B. (2001). Bilingual education teachers' beliefs about their relation to self-reported practices. *Bilingual Research Journal*, 25 (3): 275-299.





- Hammer, D. (1995). Epistemological considerations in teaching introductory physics. *Science Education*, 79 (49): 393-413.
- Handelsman, J., Miller, S. and Pfund, C. (2007). *Scientific Teaching*. New York: W.H. Freeman.
- Hashweh, M. Z. (1985). An exploratory study of teacher knowledge and teaching: The effects of science teachers' knowledge of subject-matter and their conceptions of learning on their teaching. Unpublished PhD dissertation, Stanford University, California.
- Hashweh, M. Z. (1996). Effects of science teachers' epistemological beliefs in teaching. *Journal of Research in Science Teaching*, 33 (1): 47-63.
- Hofer, B. K., and Pintrich, P. R. (1997). The development of epistemological theories: beliefs about knowledge and knowing and their relation to learning. *Review of Educational Research*, 67 (1): 88-140.
- Hofer, B.K. (2001). Personal epistemology research: Implications for learning and instruction. *Educational Psychology Review*, 13 (4): 353-382.
- Howard, B.C., McGee, S., Schwartz, N., and Purcell, S. (2000). The experience of constructivism: Transforming teacher epistemology. *Journal of Research on Computing in Education* (32) 4: 455-462.
- Jehng, J. J., Johnson, S. D., and Anderson, R. C. (1993). Schooling and students' epistemological beliefs about learning. *Contemporary Educational Psychology*, 18 (1): 23-35.
- Kardash, C. A. M., and Scholes, R. J. (1996). Effects of preexisting beliefs, epistemological beliefs, and need for cognition on interpretation of controversial issues. *Journal of Educational Psychology*, 88 (2): 260-271.
- Kardash, C. M., and Howell, K. L. (2000). Effects of epistemological beliefs and topic-specific beliefs on undergraduates' cognitive and strategic processing of dual-positional text. *Journal of Educational Psychology*, 92 (3): 524-535.
- Kegan, R. (1982). *The evolving self: Problem and process in human development*. Cambridge, MA: Harvard University Press.
- Kember, D. (1997). A reconceptualisation of the research into University academics' conceptions of teaching. *Learning and Instruction*, 7 (3): 255-275.
- King, P. M., and Kitchener, K. S. (1994). *Developing reflective judgment: Understanding and promoting intellectual growth and critical thinking in adolescents and adults*. San Francisco, CA: Jossey-Bass.
- Koc, Y., Doymus, K., Karacop, A., and Simsek, Ü. (2010). The Effects of Two Cooperative Learning Strategies on the Teaching and Learning of the Topics of Chemical Kinetics, *Journal of Turkish Science Education*, 7 (2): 53-64.
- Kuhn, D., and Weinstock, M. (2002). What matters in epistemological thinking and why does it matter? In B. K. Hofer and P. R. Pintrich (Eds.), *Personal epistemology: The psychology of beliefs about knowledge and knowing* (pp. 121-144). Mahwah, NJ: Erlbaum.
- Larochelle, M., and Desautels, J. (1991). "Of course it's just obvious": Adolescents' ideas of scientific knowledge, *International Journal of Science Education*, 13 (4): 373-389.
- Leech, N. L., Barrett, K.C. and Morgan, G.A. (2005). *SPSS for Intermediate Statistics: Use and Interpretation*. (Second Edition). NJ: Lawrence Erlbaum Associates, Inc.
- McMillan, J. H. and Schumacher, S. (2006). *Research in education: evidence-based inquiry*. (Sixth Edition). Boston, MA: Allyn and Bacon.
- Mattingly, R.M., and VanSickle, R.L. (1991). Cooperative learning and achievement in social studies: Jigsaw II. *Journal of Social Psychology*, 128 (1): 345-352.





- Murdoch, K. and Wilson, J. (2008). *Creating a Learner-centred Primary Classroom Learner-centred strategic teaching*, Taylor and Francis e-Library
- Oh, P. S. and Shin, M. K. (2005). Students' reflections on implementation of group investigation in Korean secondary science classrooms. *International Journal of Science and Mathematics Education*, 3 (2): 327-349.
- Otting, H., Zwaal, W., Tempelaar, D., and Gijsselaers, W. (2010): The structural relationship between students' epistemological beliefs and conceptions of teaching and learning, *Studies in Higher Education*, 35 (7): 741-760.
- Pajares, M. F. (1992). Teacher beliefs and educational research: cleaning up a messy construct. *Review of Educational research*, 62 (3): 307-332.
- Prawat, R. S. (1992). Teachers beliefs about teaching and learning: a constructivist perspective. *American Journal of Education*, 100 (3): 354-395.
- Prezler R. W., Dawe A., Shuster C. B., and Shuster, M. (2007). Assessment of the effects of student response systems on student learning and attitudes over a broad range of biology courses. *CBE Life Sciences Education*.(6):29-41.
- Pronzato, C.D., (2012). *Comparing Quasi-Experimental Designs and Structural Models for Policy Evaluation: The Case of a Reform of Lone Parental Welfare*, Discussion Paper No. 6803, Statistics Norway, Dondena, ISER and IZA
- Qian, G., and Alvermann, D, E. (1995). The role of epistemological beliefs and learned helplessness in secondary school students' learning science from text. *Journal of Educational Psychology*, 87 (2): 282-292.
- Qian, G., and Alvermann, D, E. (2000). Relationship between epistemological beliefs and conceptual change learning. *Reading Writing Quarterly*. 16 (1): 59-74.
- Richardson, V. (2005). *Constructivist Teacher Education: Building New Understandings* Taylor and Francis e-Library.
- Rodríguez, L., and Cano, F. (2006) The epistemological beliefs, learning approaches and study orchestrations of university students. *Studies in Higher Education*, 31 (5): 617-636.
- Samuelowicz, K., and Bain, J. D. (1992). Conceptions of teaching and learning held by academics. *Higher Education*, 24 (1): 93-111.
- Schommer, M. (1990). Effects of beliefs about the nature of knowledge on comprehension. *Journal of Educational Psychology*, 82 (3): 498-504.
- Schommer, M. (1993). Epistemological development and academic performance among secondary students. *Journal of Educational Psychology*, 85 (3): 406-411.
- Schommer, M. (1994). Synthesizing epistemological belief research: Tentative understandings and provocative confusions. *Educational Psychology Review*, 6 (4): 293-319.
- Schommer, M. (1998). The role of adults' beliefs about knowledge and learning in school, work, and everyday life. In M. C. Smith and T. Pourchot (Eds.), *Adult learning and development: Perspectives from educational psychology* (27-143). Hillsdale: Erlbaum.1998.
- Schommer, M., Calvert, C., Gariglietti, G., and Bajaj, A. (1997). The development of epistemological beliefs among secondary students: A longitudinal study. *Journal of Educational Psychology*, 89 (1): 37-40.
- Schommer, M., Crouse, A., and Rhodes, N. (1992). Epistemological beliefs and mathematical text comprehension: believing it is simple does not make it so. *Journal of Educational Psychology*, 84 (4): 435-443.





- Smith, C. L., Maclin, D., Houghton, C., and Hennessey, M. G. (2000). Sixth-grade students' epistemologies of science: The impact of school science experiences on epistemological development. *Cognition and Instruction*, 18 (3): 349-422.
- Trigwell, K., Prosser, M., and Waterhouse, F. (1999). Relations between teachers' approaches to teaching and students' approaches to learning. *Higher Education*, 37 (1): 57-70.
- Uygur, E. (2009). İlköğretim 7. Sınıf fen ve teknoloji dersi kuvvet ve Hareket ünitesinin öğretiminde işbirlikli öğrenme Yönteminin öğrenci başarısına, tutuma ve bilgi Kalıcılığına etkisi. Yayınlanmamış yüksek lisans tezi, Gazi üniversitesi Eğitim Bilimleri Enstitüsü, Ankara: Türkiye.







## **İşbirlikli Öğrenme Modelinin Vatandaşlık Dersi Öğrencilerinin Epistemolojik İnançları Üzerindeki Etkileri**

**Yrd.Doç.Dr. Ufuk ŞİMŞEK**  
Ataturk Üniversitesi-Türkiye  
ufukersegun@gmail.com

### **Genişletilmiş Özet**

**Problem:** Günümüzde hemen hemen tüm ülkelerin eğitim programları yapılandırmacı yaklaşımı yansıtmaktadır. Literatüre bakıldığında epistemolojik inançlar ile öğrenme yaklaşımları arasında yapısal ilişkiler olduğu görülmektedir. Bu çalışmada öğrencilerin epistemolojik inançlarına Jigsaw, Grup Araştırması ve Okuma-Yazma-Sunma gibi işbirlikli öğrenme modelleri ve öğretmen merkezli (geleneksel) metodun etkileri incelenmiştir.

**Yöntem:** Bu araştırma, karşılaştırmalı grup modellerinden eşit olmayan gruplar ön test-son test deney ve kontrol gruplu yarı deneysel araştırma (quasi-experimental designs) modelindedir. Çalışmanın örneklemini, 2011-2012 akademik yılında vatandaşlık bilgisi dersini alan üç farklı sınıftan toplam 193 öğrenciden oluşmaktadır. Sınıflardan biri Grup Araştırması Grubu (GAG, n=48), ikincisi Okuma-Yazma-Sunma Grubu (OYSG, n=49), üçüncüsü Jigsaw Grubu (JG, n=48 ve dördüncüsü ise Öğretmen Merkezli Grup (ÖMG, n=48) şeklinde belirlenmiştir. Çalışmada, Schommer tarafından geliştirilen ve Deryakulu ve Büyükköztürk tarafından yeniden yapılandırılan Epistemolojik inanç ölçeği kullanılmıştır. Araştırma grupları arasındaki farklılıkları belirleyebilmek için tanımlayıcı istatistikler ve tek yönlü varyans analizi (ANOVA) yapılmıştır.

**Bulgular:** Elde edilen veriler, uygulama grupları arasında epistemolojik inanç ölçeği ön ve son test puanları bakımından istatistiki olarak anlamlı farklılıklar olmadığını göstermektedir (Ön-EİÖ;  $3,187=2.025$ ,  $p>.05$ ; Son-EİÖ  $F_{3,191}= 1.934$ ,  $p>.05$  ). Bunun nedenleri olarak çalışmanın kısa bir zamanda yapılması ve yükseköğretim öğrencilerinin epistemolojik tutumlarının keskinleşmesi söylenebilir.

**Sonuç ve Öneriler:** Araştırmadan elde edilen sonuçlar, işbirlikli öğrenme modelinin uygulanmasında kullanılan grup araştırması, jigsaw ve okuma-yazma-sunma metodlarının düz anlatım yöntemi ile ders yapan öğrencilerin epistemolojik inançlarında anlamlı bir fark olmadığını ortaya koymuştur. Sonuçların böyle olmasının nedeni öğrencilerin epistemolojik inançlarının uzun yıllar boyunca şekillenmiş olması gösterilebilir. Yapılan araştırmalar uzun süreli çalışmalarda öğrencilerin inançların değişiklikler olduğunu ortaya koymaktadır (King and Kitchener 1994; Schommer 1993; Schommer, Calvert, Gariglietti, and Bajaj 1997; Kuhn and Weinstock, 2002). Örneğin, bilginin kesin ve değişmez olduğuna ya doğru ya da yanlış olduğuna inanan birey





zamanla bilginin karmaşık, göreceli, değişebilir olduğuna inanabilir. Öğrenci merkezli aktif metotlar eğitimin tüm seviyelerinde uygulanırsa, bireylerin epistemolojik inançlarının değişebileceği söylenebilir. Bu alandaki çalışmalar yapılandırıcı sınıfların geleneksel şekilde yapılandırılmış sınıflara göre daha sofistike epistemolojik tutumlar geliştirebileceğini ortaya koymaktadır. (Smith, Maclin, Houghton and Hennessey 2000).

**Anahtar Kelimeler:** İşbirlikli öğrenme, Epistemolojik inançlar, Yükseköğretim, Vatandaşlık dersi,

